

KH*B系列高压球阀

KH*B Series High Pressure Ball Valve

其它
系列



技术参数 Technical Specifications

公称压力/Nominal Pressure : 315bar
 阀体材料/Valve Body Material : 304、316
 工作温度/Operating Temperature : -30~+170 °C
 适用介质/Applicable Medium: 液压油 Hydraulic Oil

图形符号 Symbol



外形尺寸 Overall Dimension

KH*B*-SR

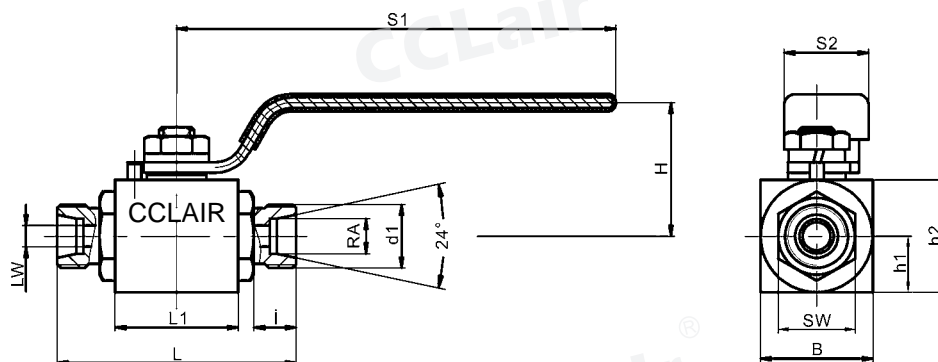

KH*B*-NPT

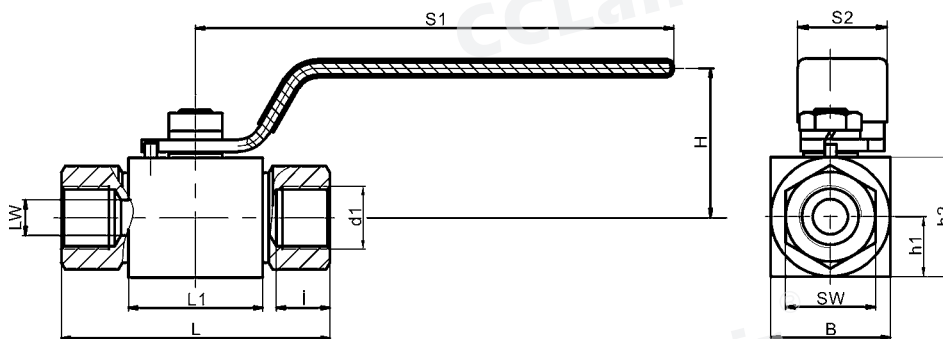

型号 Part No.	PN (bar)	DN	LW	RA	d1	i	L	L1	B	H	h1	h2	S1	S2	SW
KH1B-10-10SR	315	10	06	10	M18x1.5	12	18	38	32	09	38	32	125	24	22
KH1B-10-12SR	315	10	08	12	M20x1.5	12	18	38	32	09	38	32	125	24	27
KH1B-10-14SR	315	10	10	14	M22x1.5	14	25	55	32	12	38	32	125	24	27
KH2B-13-20SR	315	13	13	20	M30x2	16	25	55	40	12	40	40	160	30	32
KH2B-13-NPT1/2	315	13	12	/	NPT 1/2	18	28.5	64	40	12	40	8.1	160	30	32
KH2B-13-NPT3/4	315	13	12	/	NPT 3/4	18	28.5	64	40	12	40	9.6	160	30	33
KH3B-20-NPT1	315	20	20	/	NPT 3/4	20	37.5	84	50	14	50	8.1	160	30	46